

## Socket Terminals

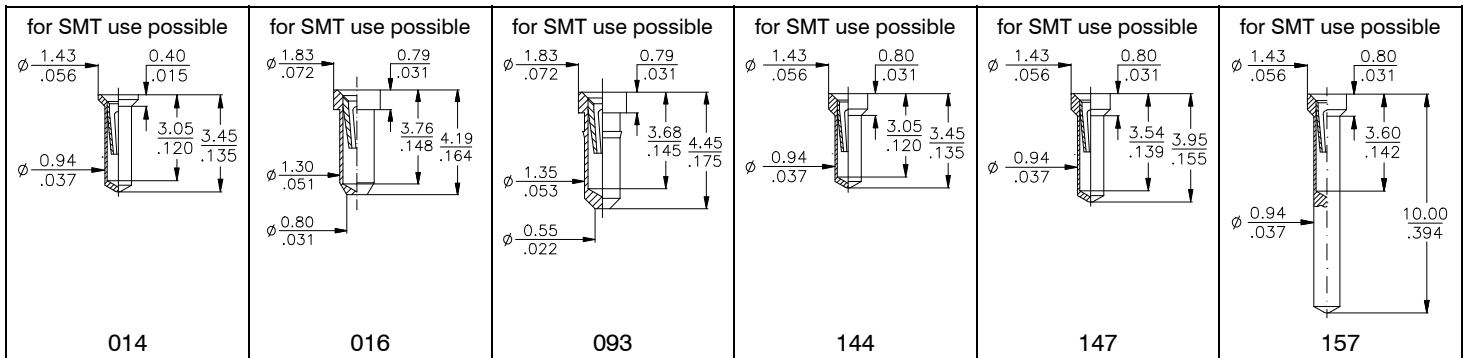

## Wire Wrap Terminals

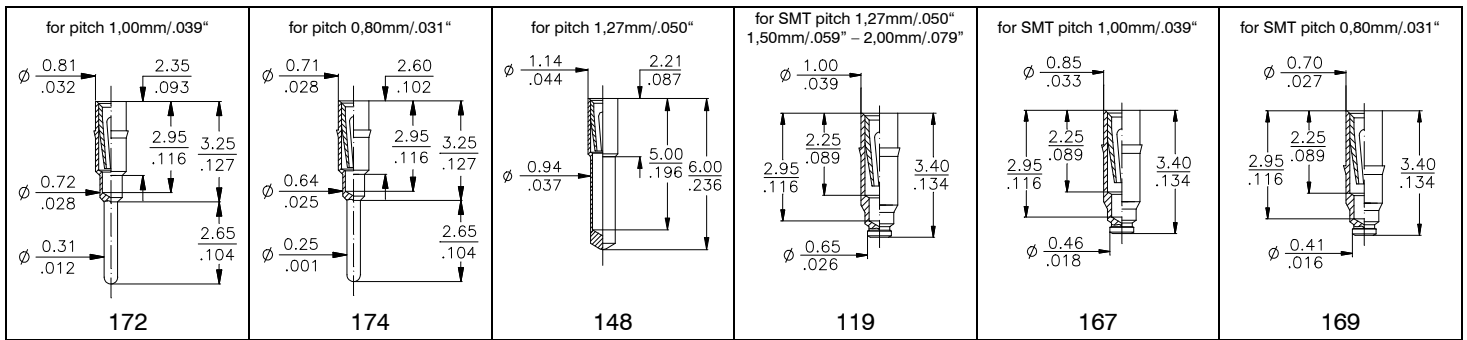
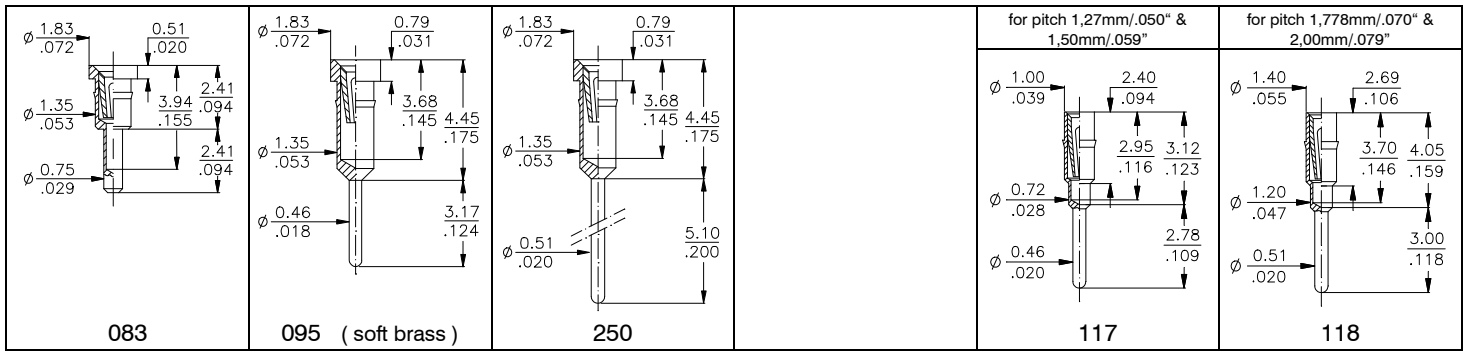
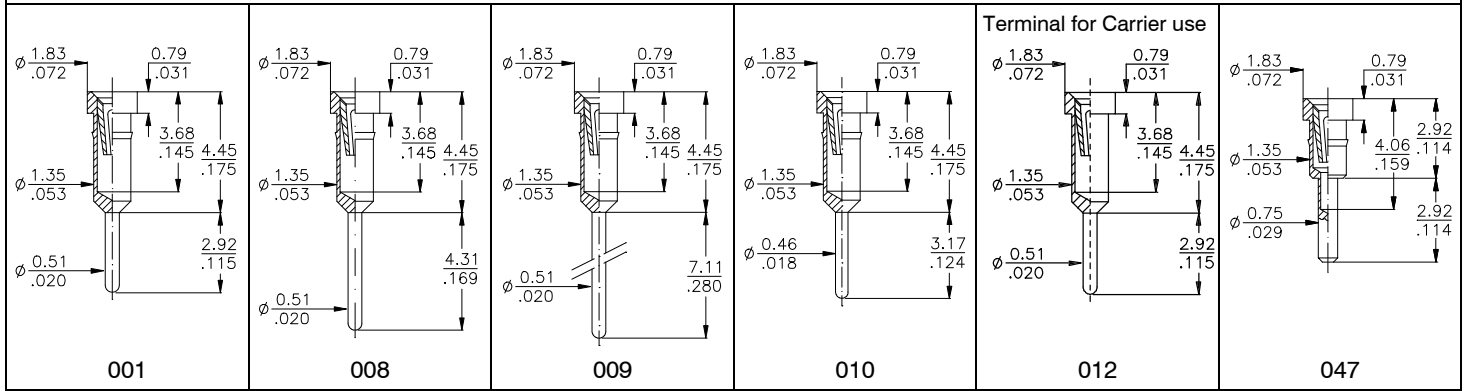
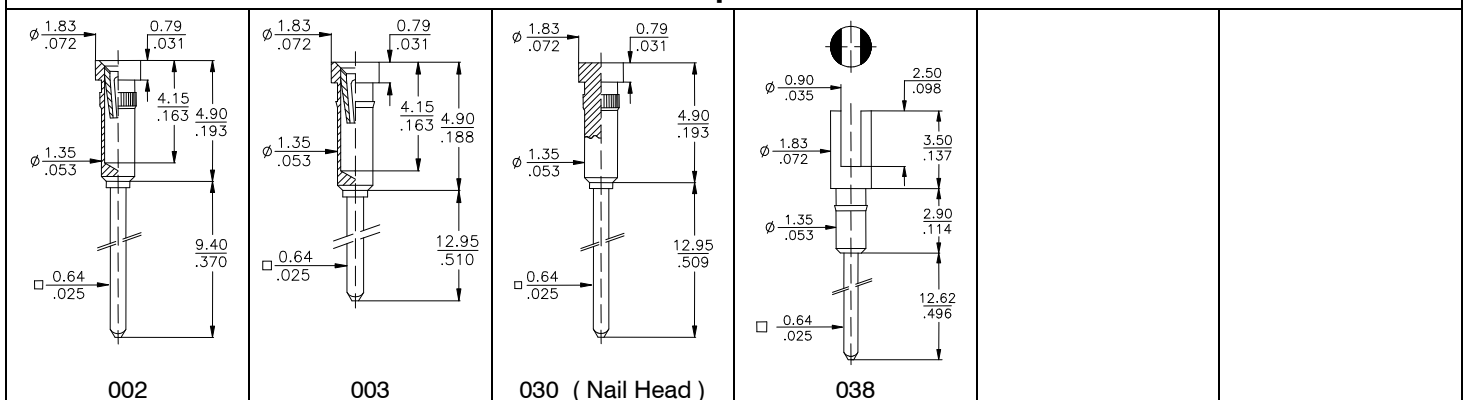

## Raised Terminals

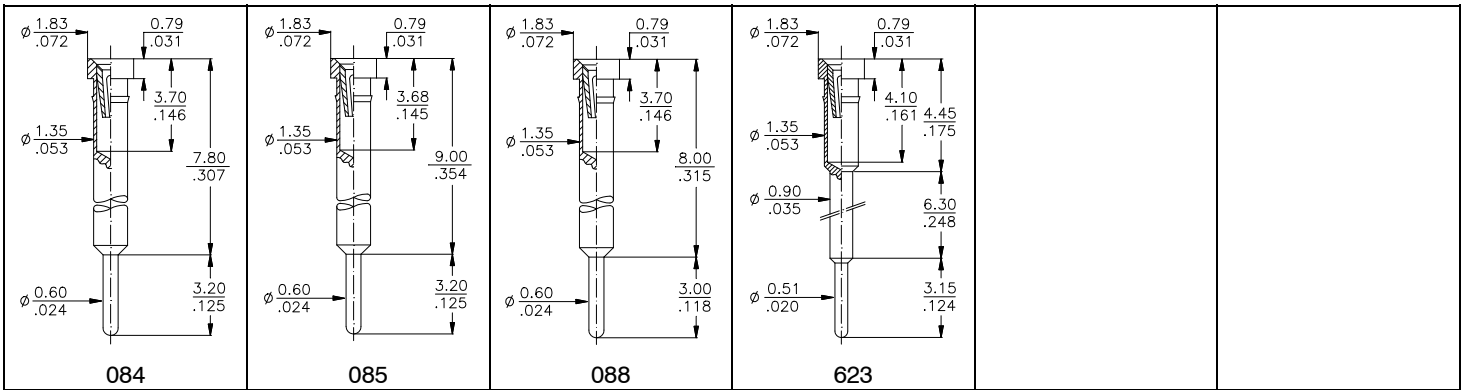
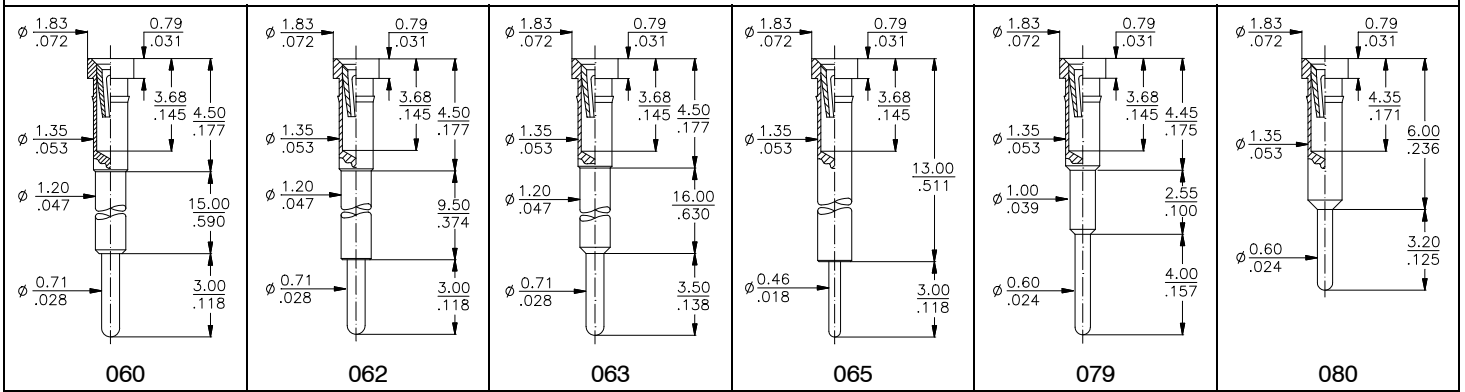

## „Jumbo“ Contact & Male Terminals

( Contact accepts 0,64mm/.025" sq. & 0,90mm/.036" dia. Pins )

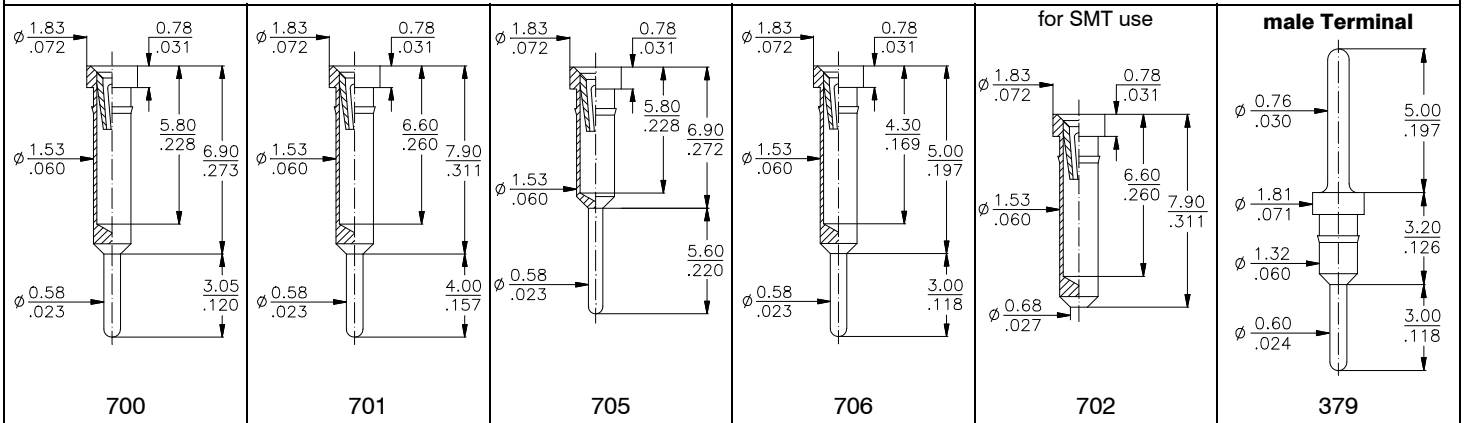

## Solder Adapter Terminals

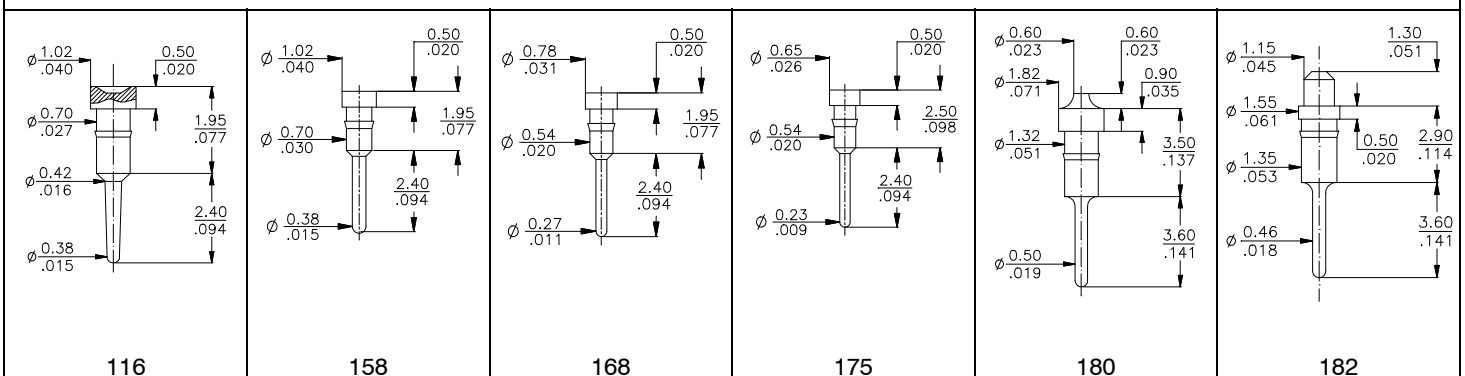

## Board to Board Terminals

|            |            |            |            |            |  |
|------------|------------|------------|------------|------------|--|
| <p>037</p> | <p>056</p> | <p>057</p> | <p>058</p> | <p>059</p> |  |
| <p>077</p> | <p>078</p> | <p>220</p> | <p>372</p> | <p>377</p> |  |
| <p>542</p> | <p>544</p> | <p>562</p> | <p>583</p> | <p>770</p> | <p>for pitch 1,27mm/.050"</p> <p>774</p> |

## Header Terminals

|            |            |                        |  |  |  |
|------------|------------|------------------------|--|--|--|
| <p>036</p> | <p>353</p> | <p>038 (Wire Wrap)</p> |  |  |  |
|------------|------------|------------------------|--|--|--|

## General Specifications for Precision Pin Sockets

### Mechanical data

|  |   |
|--|---|
| Average forces for available clip types:           |   |
| Standard type                                      | 1.80N insertion / 0.90N extraction                                      |
| Low force type                                     | 0.70N insertion / 0.25N extraction                                      |
| Super low force type                               | 0.40N insertion / 0.15N extraction                                      |
| High force type                                    | 4.00N insertion / 2.50N extraction                                      |
| „Jumbo“ contact                                    | 1.40N insertion / 0.25N extraction                                      |
| <i>Other clips and forces available on request</i> |   |
| Contact life                                       | min. 100 cycles   |
| Vibration as per EN60352-4                         | sinusoidal, 10 to 500 Hz, 10g,<br>1 octave/min, 10 cycles for each axis |
| Shock as per EN60352-4                             | half sine, 50g, 11ms, 3 shocks in 3 axes                                |
| Thermal shock as per IEC 60068-2-14                | -55°C/+125°C, 5 cycles, 30 minutes                                      |
| Solderability as per IEC 60068-2-58                | 245°C to 255°C 5 sec; Sn97Ag3 solder alloy                              |
| Dry heat steady state as per IEC 60068-2-2         | 260°C for 20 sec.   |
| Cold steady state as per IEC 60068-2-1             | -55°C, 2h   |
| Damp heat cyclic as per IEC 60068-2-30             | 55°C, 90-100%rH, 24h  |
| Moisture sensitivity Level (JEDEC J-STD-020C)      | 2 for PBT & Nylon<br>1 for all other materials                          |
| PCB holes for 2.54mm pitch standard connectors     | 1.00mm diameter   |
| Coplanarity thru-hole                              | 0.30mm  |
| General tolerances                                 | +/- 0.10mm  |

### Operating temperature (standard)

-55°C to +125°C

### Processing temperature

|  |  |
|--|--|
| injection molded insulator (high temp) | +250°C +0/-5°C for 20~40 sec.<br>(reflow solder) |
| injection molded insulator (PBT)       | +250°C +0/-5°C for 10 sec.<br>(wave solder only) |
| Epoxy FR4 (Standard)                   | +220°C min. for 10 sec.                          |
| Epoxy FR4 (hi temp)                    | +260°C min. for 60 sec.                          |

### Electrical data

|  |                            |
|--|----------------------------|
| Contact resistance at 1A                           | 4,3 mΩ typ.                |
| Current rating (except „Jumbo“ contact)            | 1A max.                    |
| „Jumbo“ contact                                    | 3A max.                    |
| Contact capacitance at 1MHz                        | 2pF max.                   |
| Insulation resistance at 500V DC for std & hi-temp | 5 × 10 <sup>9</sup> Ω min. |
| Insulation resistance at 500V DC for FR4 Epoxy     | > 10 <sup>4</sup> MΩ       |
| Breakdown voltage at 60 Hz                         | 500 V AC min.              |
| Contact resistance after 1000 ins./ext. cycles     | ≤ 7 mΩ                     |

### Material (RoHS compliant)

|   |  |
|---|--|
| Standard temperature plastic: PBT<br>UL 94 V-0            | 14, 15, 16, 23, 17, 19, 20, 24<br>25, 26, 27, 29   |
| High-temp plastic: Nylon, PCT, SPS, PPS, LCP<br>UL 94 V-0 | 5, 6, 7, 8, 9, 10, 11, 12, 13,<br>14, 15, 16, 21, 22, 20, 25, 26<br>27, 28, 33, 34, 35, 36, 37, 38<br>39, 40, 41, 42, 43 |
| Epoxy FR4:<br>UL 94 V-0 & UL 94 V-1                       | 32, 5, 6, 7, 18, 22, 24, 29  |
| PBT, Nylon, PCT, SPS, PPS, LCP & Epoxy FR4                | If necessary pls. contact E-tec<br>for Material specification.   |
| Terminal: CuZn  |  |
| Contact: BeCu   |  |

### Male pin dimensions for standard clip (except „Jumbo Contact“)

(DIN 41 870, IEC 191 for square IC-legs)

| DIM   | min.                 | max.                 |
|-------|----------------------|----------------------|
| „A“ ∅ | <u>0,42</u><br>.016" | <u>0,56</u><br>.022" |
| „B“ □ | <u>0,36</u><br>.014" | <u>0,55</u><br>.023" |
| „C“ □ | <u>0,20</u><br>.008" | <u>0,30</u><br>.014" |

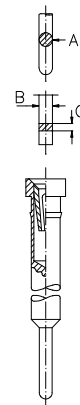

## General information concerning the E-tec interconnect products

### Plating:

- Standard tin plating:  
min. 2.50µm Sn (*leadfree*) over Ni
- Standard gold plating:  
flash, max. 0,10µm Au over Ni
- Higher gold platings are offered on request

### Specifications:

The data contained in this catalog is of general nature and refers to standard products. For example a „Current rating“ at an ambient temperature of 25° C reflects the value per individual contact. Should you require any further data or test reports, you can obtain this information from your nearest E-tec sales office.

The E-tec connectors conform with signal integrity requirements at high data and frequency rates. However we cannot offer a general information about the max. frequency or data transmission rate. For such a statement, it would require more information about the chosen configuration and pin-out, the length of the cable and/or any other specific requirements regarding the application itself and its related signal integrity.

E-tec SMT connectors, male or female, are offered with a coplanarity of max. 0,10mm. They are adapted to all modern SMT soldering processes and they can be handled easily with all currently existing placing techniques. Customers may choose between various packaging options, such as tray, tube and tape & reel.

### GENERAL POLICY

All information contained in this catalog, including illustrations, specifications and dimensions are accurate to the best of our knowledge, and reflect the status as at the date of publication. Due to technical progress, it is subject to change without notice. Application information is informational in nature and shall not be construed to warrant suitability of products for any particular purpose as performance may vary depending on the conditions to which a product is subjected. Unless otherwise confirmed at the time of order, all E-tec products are non cancellable and non returnable items (NCNR). E-tec products are warranted for 30 days and the warranty is limited strictly to replacement of products. This warranty does not cover any claims for natural wear and tear, nor for any compensations, such as loss of production, loss of use, loss of orders, loss of profit, nor any other direct or indirect damages.